

3-Axes-Manipulator

KM 931

The 3-Axes-Manipulator KM 931 features maximum manoeuvrability of your attachments at the loader crane's tip – and provides flexibility of the loader crane's use in any arc position. For mobile and fix mounted loader cranes.

- **3-axes-manipulator: maneuverability** by three hydraulic functions: gripping, rotating and tilting (3rd hydraulic circuit needed). Endless rotation.
- **High loads** of 500 - 1000 kg / 1100 - 2200 lbs are handled by **KINSHOFER**-Manipulators.
- **Precise positioning** by the **KINSHOFER** rotator with
 - mechanically acting hydraulic brake for the rotating movement (KM 931-500).
 - or with a self-locking worm drive (KM 931-1000).

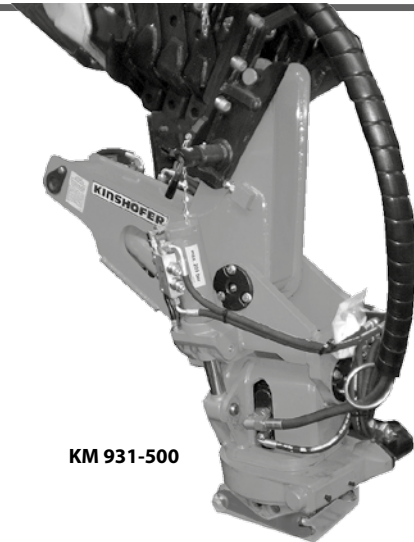

KM 931-500

3-Axes-Manipulator KM 931

Type	max. Load (kg / lbs)	Slewing angle	Tilting angle	Rotation	Self weight (kg / lbs)
KM 931-500	500 / 1100	135°	± 40°	360° endless	200 / 440
KM 931-1000	1000 / 2200	130°	± 40°	360° endless	290 / 638

Package consists of: manipulator, **KINSHOFER** rotator (KM 931-500) or worm drive (KM931-1000), non-return valve

Note: tubes or poles must always be taken at / near their balance point !

Accessories

Type	Description
KM 980-2	solenoid valve for additional oil circuit to change over to 3 circuits (for gripping, lifting, turning) when only 2 circuits are available, ready for mounting – 12 V or 24 V, working pressure max. 25 Mpa / 3600 psi, oil flow 60 l/min / 15.85 GPM (do-it-yourself assembly)
KM 980-2 c	solenoid valve KM 980-2 complete attachment kit including assembly components, hose guard, hoses and mounting on the KM 931 manipulator – 12 V or 24 V, working pressure max. 25 Mpa / 3600 psi, oil flow 60 l/min / 15.85 GPM

Requirements of Excavator

Three hydraulic circuits needed

Operating pressure:

max. 20 MPa (200 bar) / 2880 psi

Oil flow:

20 - 40 l/min / 5.28 - 10.57 GPM

Technical Drawings – Example of Use

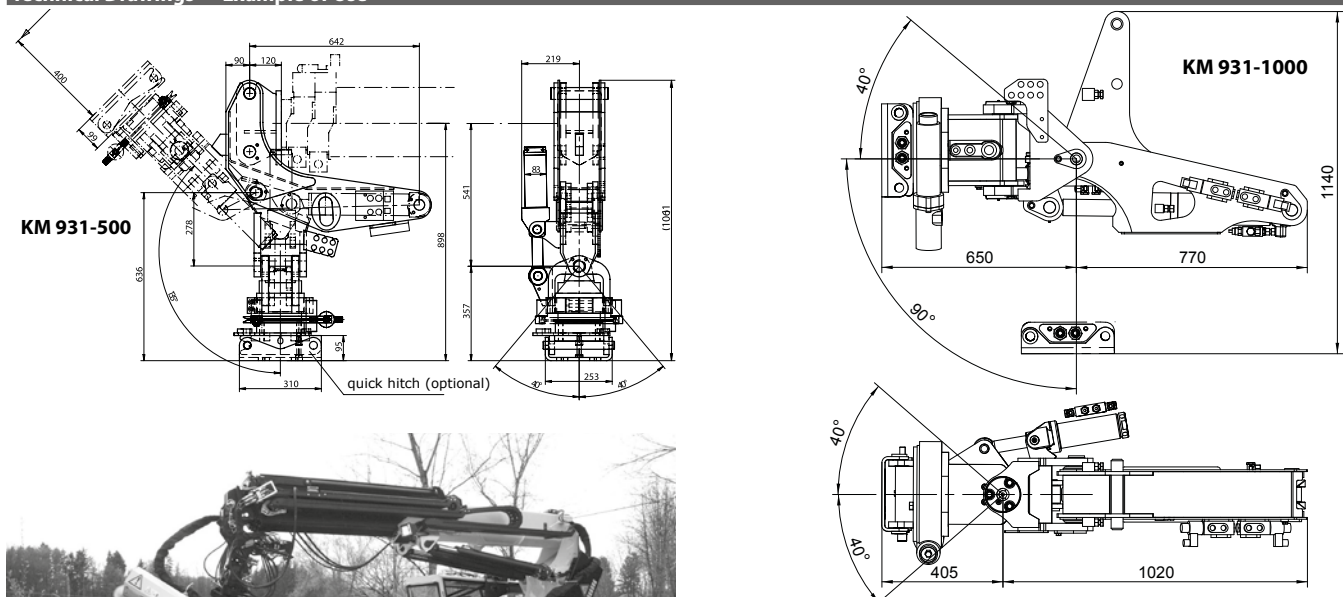

KM 931-500 at a fix crane on a railway wagon (here with a branch saw)